

## Hand Crank Reels

Up to 150' fuel gas  
Up to 200' 12/3 cable



Ideal for applications where space, weight and flexibility are key, these reels are designed for manual winding of air/water/fuel gases hose, electric cord and welding cable. Versatile in function, select configurations to suit specific needs. Safe-T-Reels offer trouble-free management of large capacities of hose or cord.



Side-by-side combinations

T-2462-0



Stacked combinations

T-2464-0

Model without cable	AMP	Reel Capacity		Cable		Shipping Weight		Size Index #
		ft	m	AWG	Cond	lbs	kg	
<b>Single Power Cable - 3 Conductor</b>								
T-1535-003	30	150	45	8	3	18.5	5	1
T-1535-083-100*	33	100	30	8	3	50	23	1
T-1535-103-200*	24	200	61	10	3	81	37	1
T-1535-123-100*	25	100	30	12	3	46	21	1
T-1535-123-200*	20	200	61	12	3	71	32	1

\*Includes cable.

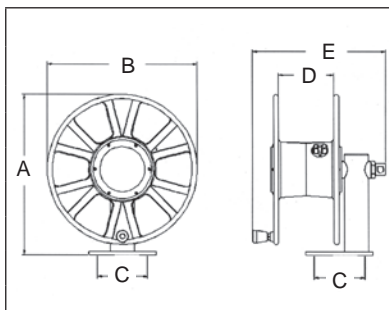

Dimensions - Size Index						
	1		2		3	
	in	mm	in	mm	in	mm
<b>A</b>	19	483	19	483	19	483
<b>B</b>	18	457	18	457	18	457
<b>C</b>	6	152	6	152	6	152
<b>D</b>	6 1/2	165	6 1/2	165	12 1/2	165
<b>E</b>	15 3/4	401	16 1/4	412	21 3/4	552

Four 1/2" (12.7 mm) diameter mounting holes.

Model without hose	Hose I.D.		Hose O.D.		Reel Capacity		Pressure		Shipping Weight		Size Index #
	in	mm	in	mm	ft	m	psi	bar	lbs	kg	
<b>Single Spool Air/Water Hose Reels</b> Maximum Temperature 150 °F (65 °C)											
T-1115-08	1/2	13	.844	21	150	46	300	21	18	8	1
T-1116-08	1/2	13	.844	21	250	76	300	21	22	10	3
T-1117-12	3/4	19	1.188	30	50	15	250	17	18	8	1
T-1118-12	3/4	19	1.188	30	75	23	250	17	22	10	3
<b>Single Spool Oxygen/Acetylene T-Grade Seals</b> Maximum Temperature 150 °F (65 °C)											
CA T-1225-04	1/4	6	.530	13	150	45	200	14	19	9	2
T-1225-04-100T*	1/4	6	.530	13	100	30	200	14	44	20	2
T-1226-06	3/8	10	.625	16	100	30	200	14	19	9	2

\*Includes hose.

### Detail of heavy duty shaft

with tapered roller bearing for high rigidity



Shaft sizes are 1" to 1.25" in diameter, supported by tapered roller bearings with 2" to 2.3" housings.

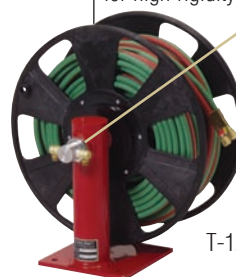

T-1225-04-100T

Model without cable	AMP	Reel Capacity		Shipping Weight		Size Index #
		ft	m	lbs	kg	
<b>Single Welding Cable</b> 600 V, 2/0 Cable						
T-1460-0	250	200	61	32	15	2
<b>Dual Side-by-Side Welding Cable (2)</b> 600 V, 2/0 Cable						
CA T-2462-0	250	200	61	51	23	5
<b>Dual Stacked Welding Cable (2)</b> 600 V, 2/0 Cable						
CS T-2464-0	250	200	61	62	28	4
<b>Dual Side-by-Side Power Cable/Air Hose</b>						
T-2735-2-0*	35	200	61	40	18	5
		150	45			

\*Air hose side has 1/2" (12.7mm) inlet.

Dimensions - Size Index						
	4		5			
	in	mm		in	mm	
<b>A</b>	38	965	19	483		
<b>B</b>	18	457	18	457		
<b>C</b>	6	152	6	152		
<b>D</b>	6 1/2	165	6 1/2	165		
<b>E</b>	16 1/4	737	29	737		

Four 1/2" (12.7 mm) diameter mounting holes.

**Caution:** Compressed air hoses should not be converted to oxygen service. Compressed air hoses are often contaminated with an oil coating, which can react explosively when oxygen is introduced. Oxygen/Acetylene cannot be combined with welding cable or power cord. **Note:** Models listed are without hose and/or cable except where listed. Weights listed above are actual product weight without packaging materials. Safe-T-Reels are available with cable or hose and in various combinations. Please consult Reelcraft customer service for additional information.

Models listed with an icon can ship same day upon request when the order is received by 11:30 AM Eastern Time for quantities of 10 or fewer.

IA Indiana Warehouse

IC Indiana & California Warehouses

CA California Warehouse

CA Canadian Warehouse

Customer Service: 1.855.634.9109

All Other Calls: 1.800.444.3134

**REELCRAFT**®