

Model 500B Series

Laser Diode Drivers



User's Manual



Newport®
Experience | Solutions

EU Declaration of Conformity

We declare that the accompanying product, identified with the **CE** mark, complies with requirements of the Electromagnetic Compatibility Directive, 2001/108/EC and the Low Voltage Directive 2006/95/EC.

Model Number: Model 500B Series Laser Diode Drivers

Year **CE** mark affixed: 2003

Type of Equipment: Electrical equipment for measurement, control and laboratory use

Standards Applied:

Compliance was demonstrated to the following standards to the extent applicable:

BS EN61326-1: 2006 “Electrical equipment for measurement, control and laboratory use – EMC requirements”

BS EN 61010-1:2010, “Safety requirements for electrical equipment for measurement, control and laboratory use”



Todd McFarland
Senior Electrical Engineer
31950 E Frontage Rd
Bozeman, MT, USA

Warranty

Newport Corporation warrants that this product will be free from defects in material and workmanship and will comply with Newport's published specifications at the time of sale for a period of one year from date of shipment. If found to be defective during the warranty period, the product will either be repaired or replaced at Newport's option.

To exercise this warranty, write or call your local Newport office or representative, or contact Newport headquarters in Irvine, California. You will be given prompt assistance and return instructions. Send the product, freight prepaid, to the indicated service facility. Repairs will be made and the instrument returned freight prepaid. Repaired products are warranted for the remainder of the original warranty period or 90 days, whichever first occurs.

Limitation of Warranty

The above warranties do not apply to products which have been repaired or modified without Newport's written approval, or products subjected to unusual physical, thermal or electrical stress, improper installation, misuse, abuse, accident or negligence in use, storage, transportation or handling. This warranty also does not apply to fuses, batteries, or damage from battery leakage.

THIS WARRANTY IS IN LIEU OF ALL OTHER WARRANTIES, EXPRESSED OR IMPLIED, INCLUDING ANY IMPLIED WARRANTY OF MERCHANTABILITY OR FITNESS FOR A PARTICULAR USE. NEWPORT CORPORATION SHALL NOT BE LIABLE FOR ANY INDIRECT, SPECIAL, OR CONSEQUENTIAL DAMAGES RESULTING FROM THE PURCHASE OR USE OF ITS PRODUCTS.

First printing 2003

© 2003 by Newport Corporation, Irvine, CA. All rights reserved. No part of this manual may be reproduced or copied without the prior written approval of Newport Corporation.

This manual has been provided for information only and product specifications are subject to change without notice. Any change will be reflected in future printings.

Newport Corporation
1791 Deere Avenue
Irvine, CA, 92606
USA

Part No. 90036888_03 December 2013

Confidentiality & Proprietary Rights

Reservation of Title:

The Newport programs and all materials furnished or produced in connection with them ("Related Materials") contain trade secrets of Newport and are for use only in the manner expressly permitted. Newport claims and reserves all rights and benefits afforded under law in the Programs provided by Newport Corporation.

Newport shall retain full ownership of Intellectual Property Rights in and to all development, process, align or assembly technologies developed and other derivative work that may be developed by Newport. Customer shall not challenge, or cause any third party to challenge the rights of Newport.

Preservation of Secrecy and Confidentiality and Restrictions to Access:

Customer shall protect the Newport Programs and Related Materials as trade secrets of Newport, and shall devote its best efforts to ensure that all its personnel protect the Newport Programs as trade secrets of Newport Corporation. Customer shall not at any time disclose Newport's trade secrets to any other person, firm, organization, or employee that does not need (consistent with Customer's right of use hereunder) to obtain access to the Newport Programs and Related Materials. These restrictions shall not apply to information (1) generally known to the public or obtainable from public sources; (2) readily apparent from the keyboard operations, visual display, or output reports of the Programs; 3) previously in the possession of Customer or subsequently developed or acquired without reliance on the Newport Programs; or (4) approved by Newport for release without restriction.

Trademarks

The Newport logo is a registered trademark of Newport Corporation in Austria, Barbados, Benelux, Canada, the People's Republic of China, Denmark, France, Germany, Great Britain, Ireland, Japan, the Republic of Korea, Spain, Sweden, and the United State. Newport is a registered trademark of Newport Corporation in Austria, Barbados, Benelux, the People's Republic of China, Denmark, France, Germany, Ireland, Japan, the Republic of Korea, Spain, and Sweden.

Service Information

This section contains information regarding factory service for the source. The user should not attempt any maintenance or service of the system or optional equipment beyond the procedures outlined in this manual. Any problem that cannot be resolved should be referred to Newport Corporation.

Technical Support Contacts

North America & Asia

Newport Corporation Service Dept.

1791 Deere Ave. Irvine, CA 92606

Telephone: (949) 253-1694

Telephone: (800) 222-6440 x31694

Europe

Newport/MICRO-CONTROLE S.A.

Zone Industrielle

45340 Beaune la Rolande, FRANCE

Telephone: (33) 02 38 40 51 56

Asia

Newport Opto-Electronics Technologies

中国 上海市 爱都路 253号 第3号楼 3层
C部位, 邮编 200131

253 Aidu Road, Bld #3, Flr 3, Sec C,
Shanghai 200131, China

Telephone: +86-21-5046 2300

Fax: +86-21-5046 2323

Newport Corporation Calling Procedure

If there are any defects in material or workmanship or a failure to meet specifications, promptly notify Newport's Returns Department by calling 1-800-222-6440 or by visiting our website at www.newport.com/returns within the warranty period to obtain a **Return Material Authorization Number (RMA#)**. Return the product to Newport Corporation, freight prepaid, clearly marked with the RMA# and we will either repair or replace it at our discretion. Newport is not responsible for damage occurring in transit and is not obligated to accept products returned without an RMA#.

E-mail: rma.service@newport.com

When calling Newport Corporation, please provide the customer care representative with the following information:

- Your Contact Information
- Serial number or original order number
- Description of problem (i.e., hardware or software)

To help our Technical Support Representatives diagnose your problem, please note the following conditions:

- Is the system used for manufacturing or research and development?
- What was the state of the system right before the problem?
- Have you seen this problem before? If so, how often?
- Can the system continue to operate with this problem? Or is the system non-operational?
- Can you identify anything that was different before this problem occurred?

This page is intentionally left blank

Table of Contents

EU Declaration of Conformity.....	ii
Warranty.....	iii
Technical Support Contacts	v
Table of Contents	vii
List of Figures and Tables.....	x

1 Safety Precautions 11

1.1 Definitions and Symbols	11
1.1.1 General Warning or Caution	11
1.1.2 Electric Shock.....	11
1.1.3 European Union CE Mark	11
1.1.4 CDRH- Center for Devices and Radiological Health.....	12
1.1.5 Alternating voltage symbol	12
1.1.6 On	12
1.1.7 Off.....	13
1.1.8 Fuses	13
1.1.9 Frame or Chassis	13
1.2 Warnings and Cautions.....	14
1.2.1 General Warnings.....	14
1.2.2 General Cautions	15
1.2.3 Summary of Warnings and Cautions.....	15
1.3 Location of Warnings	17
1.3.1 Rear Panel.....	17

2 General Information 19

2.1 Introduction	19
2.2 Specifications	20
2.3 Accessories	21

3 Getting Started 23

3.1 Unpacking and Handling	23
3.2 Inspection for Damage	23
3.3 Available Options and Accessories	23
3.4 Parts List.....	24
3.5 Choosing and Preparing a Suitable Work Surface	24
3.6 Electrical Requirements.....	24
3.7 Power Supplies	25

4	System Operation	27
4.1	Front Panel.....	27
4.1.1	AC Power Switch	27
4.1.2	MOD.....	27
4.1.3	Range Switch.....	28
4.1.4	Mode Switch.....	28
4.1.5	OUTPUT ON Switch and Indicator	28
4.1.6	Laser Enable	29
4.1.7	Display Section.....	29
4.1.8	Control Knob.....	30
4.2	Rear Panel.....	30
4.2.1	USB Interface	30
4.2.2	PD Bias Adjustment	30
4.2.3	Bandwidth Select Switch.....	31
4.2.4	Photodiode BNC Input	31
4.2.5	Output Connector	31
4.2.6	Output Connections	31
4.2.7	Chassis GND	31
4.2.8	AC Power Inlet	31
4.2.9	Frame or Chassis Terminal.....	32
4.2.10	Power Inlet Socket.....	32
5	Computer Interfacing	33
5.1	Memory	33
5.2	Interlock Operation.....	33
5.3	Commands and Queries.....	33
6	Software Application	47
6.1	Overview	47
6.2	Connection.....	47
6.3	General Usage	48
6.3.1	LDD Tab.....	48
6.3.2	TEC Tab	49
6.4	Menu Structure	49
7	Principles of Operation	51
7.1	Introduction	51
7.2	Laser Diode Handling Precautions.....	51
7.3	Laser Diode Connections	52

7.3.1	9mm and 5.6mm Laser Diode Packages	53
7.3.2	Telecommunication Laser Diode Packages.....	54
7.4	Grounding the Laser Diode	56
7.5	Model 500B Series Setup	56
7.5.1	Using the Interlock Feature	56
7.5.2	Rack Mounting Model 500B Series Units.....	56
7.5.3	Model 500B Series Operation Checklist	56

8 Maintenance and Service 59

8.1	Enclosure Cleaning.....	59
8.2	Fuse Replacement.....	59
8.3	Obtaining Service	60
8.4	Service Form	61

List of Figures

Figure 1	General Warning or Caution Symbol	11
Figure 2	Electrical Shock Symbol	11
Figure 3	CE Mark	11
Figure 4	Alternating Voltage Symbol	12
Figure 5	On Symbol	12
Figure 6	Off Symbol	13
Figure 7	Fuse Symbol	13
Figure 8	Frame or Chassis Terminal Symbol	13
Figure 9	AC Receptacle Warning Label	15
Figure 10	Locations of warnings on the rear panel	17
Figure 11	Front Panel Layout (501B shown)	27
Figure 12	Rear Panel	30
Figure 13	Application front panel (TEC Tab)	47
Figure 14	Application front panel when communicating (LDD Tab)	48
Figure 15	Laser Diode Protection Circuit	52
Figure 16	Laser Diode/Photodiode package types with pin assignments	53
Figure 17	Laser Diode/Photodiode configurations and connections to 500B Series LDDs	54
Figure 18	Telecommunication laser diode packages and connections to 500B Series LDDs	55
Figure 19	Fuse Replacement	59

List of Tables

Table 1	General Specifications	20
Table 2	Environmental Specifications	21
Table 3	Command Summary	35

1 Safety Precautions

1.1 Definitions and Symbols

The following terms and symbols are used in this documentation and also appear on the Model 500B Series Laser Diode Drivers where safety-related issues occur.

1.1.1 General Warning or Caution



Figure 1

General Warning or Caution Symbol

The Exclamation Symbol in the figure above appears in Warning and Caution tables throughout this document. This symbol designates an area where personal injury or damage to the equipment is possible.

1.1.2 Electric Shock



Figure 2

Electrical Shock Symbol

The Electrical Shock Symbol in the figure above appears throughout this manual. This symbol indicates a hazard arising from dangerous voltage. Any mishandling could result in irreparable damage to the equipment, and personal injury or death.

1.1.3 European Union CE Mark



Figure 3

CE Mark

The presence of the CE Mark on Newport Corporation equipment means that it has been designed, tested and certified as complying with all applicable European Union (CE) regulations and recommendations.

1.1.4 CDRH- Center for Devices and Radiological Health

Model 500B Series Laser Diode Drivers has been designed and tested to comply with all applicable Center for Devices and Radiological Health (CDRH) regulations and recommendations. Within FDA, the Center for Devices and Radiological Health (CDRH) develops and implements national programs to protect the public health in the fields of radiation-emitting electronic products.

1.1.5 Alternating voltage symbol



Figure 4

Alternating Voltage Symbol

This international symbol implies an alternating voltage or current.

1.1.6 On



Figure 5

On Symbol

The On Symbol in the figure above represents a power switch position on the Model 500B Series Laser Diode Drivers. This symbol represents a Power On condition.

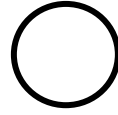
1.1.7 Off*Figure 6**Off Symbol*

The Off Symbol in the figure above represents a power switch position on the Model 500B Series Laser Diode Drivers. This symbol represents a Power Off condition.

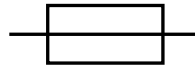
1.1.8 Fuses*Figure 7**Fuse Symbol*

The fuse symbol in the figure above identifies the fuse location on the Model 500B Series Laser Diode Drivers.

1.1.9 Frame or Chassis*Figure 8**Frame or Chassis Terminal Symbol*

The symbol in the figure above appears on the Model 500B Series Laser Diode Drivers. This symbol identifies the frame or chassis terminal

1.2 Warnings and Cautions

The following are definitions of the Warnings, Cautions and Notes that are used throughout this manual to call your attention to important information regarding your safety, the safety and preservation of your equipment or an important tip.

	<p>WARNING</p> <p>Situation has the potential to cause bodily harm or death.</p>
---	---

	<p>CAUTION</p> <p>Situation has the potential to cause damage to property or equipment.</p>
---	--

NOTE

Additional information the user or operator should consider.

1.2.1 General Warnings

Observe these general warnings when operating or servicing this equipment:

- Heed all warnings on the unit and in the operating instructions.
- Do not use this equipment in or near water.
- This equipment is grounded through the grounding conductor of the power cord.
- Route power cords and other cables so they are not likely to be damaged.
- Disconnect power before cleaning the equipment. Do not use liquid or aerosol cleaners; use only a damp lint-free cloth.
- Lockout all electrical power sources before servicing the equipment.
- To avoid fire hazard, use only the specified fuse(s) with the correct type number, voltage and current ratings as referenced in the appropriate locations in the service instructions or on the equipment. Only qualified service personnel should replace fuses.
- To avoid explosion, do not operate this equipment in an explosive atmosphere.
- Qualified service personnel should perform safety checks after any service.

1.2.2 General Cautions

Observe these cautions when operating or servicing this equipment:

- Before applying power, carefully read the warning label placed over the AC power input receptacle in back of the instrument.

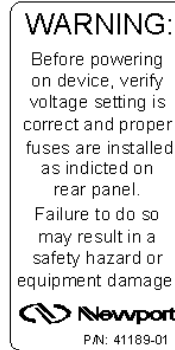

Figure 9





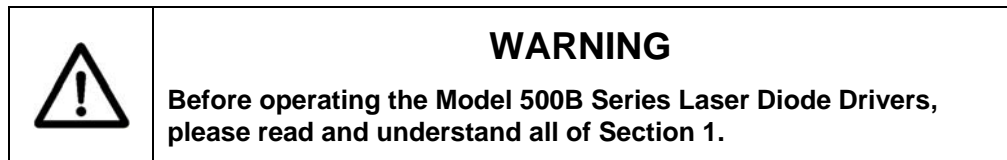

AC Receptacle Warning Label

- If this equipment is used in a manner not specified in this manual, the protection provided by this equipment may be impaired.
- To prevent damage to equipment when replacing fuses, locate and correct the problem that caused the fuse to blow before re-applying power.
- Do not block ventilation openings.
- Use only the specified replacement parts.
- Follow precautions for static sensitive devices when handling this equipment.
- This product should only be powered as described in the manual.
- There are no user-serviceable parts inside the Model 500B Series Laser Diode Drivers.
- To prevent damage to the equipment, read the instructions in the equipment manual for proper input voltage.
- Adhere to good laser safety practices when using this equipment.

1.2.3 Summary of Warnings and Cautions

The following general warning and cautions are applicable to this instrument:



	<p style="text-align: center;">WARNING</p> <p>Do not attempt to operate this equipment if there is evidence of shipping damage or you suspect the unit is damaged. Damaged equipment may present additional hazards to you. Contact Newport technical support for advice before attempting to plug in and operate damaged equipment.</p>
	<p style="text-align: center;">WARNING</p> <p>To avoid electric shock, connect the instrument to properly earth-grounded, 3-prong receptacles only. Failure to observe this precaution can result in severe injury.</p>
	<p style="text-align: center;">WARNING</p> <p>To reduce the risk of electric shock or damage to the instrument, turn the power switch off and disconnect the power cord before replacing a fuse.</p>
	<p style="text-align: center;">WARNING</p> <p>Before cleaning the enclosure of the Model 500B Series Laser Diode Drivers, the AC power cord must be disconnected from the wall socket.</p>
	<p style="text-align: center;">CAUTION</p> <p>Make sure that the selector is set at the position which corresponds to your mains voltage.</p>
	<p style="text-align: center;">CAUTION</p> <p>There are no user serviceable parts inside the Model 500B Series Laser Diode Drivers. Work performed by persons not authorized by Newport Corporation will void the warranty. For instructions on obtaining warranty repair or service, please refer to Section 8.</p>
	<p style="text-align: center;">CAUTION</p> <p>All units are factory preset to operate at 108-132VAC, 60Hz</p>

1.3 Location of Warnings

1.3.1 Rear Panel

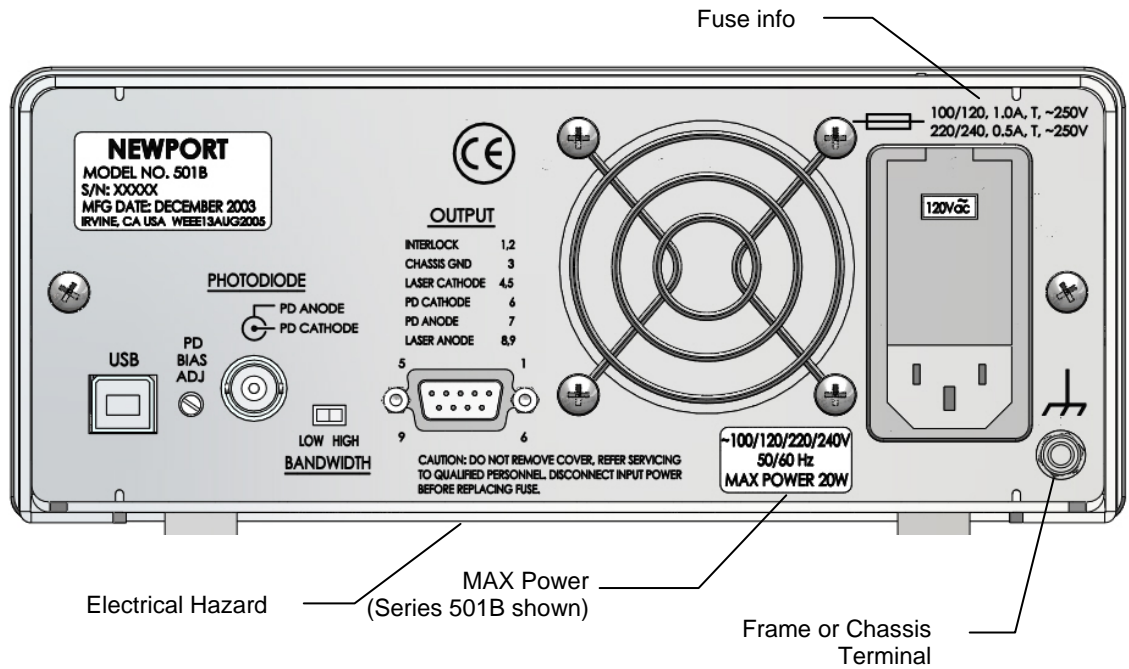

Figure 10

Locations of warnings on the rear panel

NOTE

The Model 500B-Series Laser Diode Drivers are intended for use in an industrial laboratory environment. Use of these products in other environments, such as residential, may result in electromagnetic compatibility difficulties due to conducted as well as radiated disturbances.

Waste Electrical and Electronic Equipment (WEEE)

Figure 11

WEEE Directive Symbol

This symbol on the product or on its packaging indicated that this product must not be disposed of with regular waste. Instead, it is the user responsibility to dispose of waste equipment according to the local laws. The separate collection and recycling of the waste equipment at the time of disposal will help to conserve natural resources and ensure that it is recycled in a manner that protects human health and the environment. For information about where the user can drop off the waste equipment for recycling, please contact your local Newport Corporation representative.

2 General Information

2.1 Introduction

The **500B Series Laser Diode Drivers** offer all the performance of the most advanced drivers for a fraction of the price. All models are electrically quiet and stable enough for use in the most demanding applications such as spectroscopy, fiber optic communications and all disciplines requiring highly stable optical power from a laser.

Intuitive front panel controls make these instruments extremely simple to use. There are two operating modes: constant current and constant laser power.

Dual current-level selection lets you optimize current resolution settings by precisely varying the output to the laser diode.

Comprehensive laser diode safety features and user safety have been thoroughly analyzed and designed into every 500B Series Laser Diode Driver, complying with CE and CDRH standards. Refer to Section 1, Safety Precautions for more details.

Redundant FET and relay shorting circuits protect the laser diode at the beginning of the slow turn-on sequence. After a short delay, the output current slowly ramps to your preset operating level. The current limit setting is fully independent.

External analog modulation allows you to control the voltage or modulate the output. In the high bandwidth mode, you can modulate the laser up to 1000 kHz (**Model 501B**). For precision laser output power control, or wavelength tuning with external control circuitry, you can slowly modulate the laser output in the low bandwidth mode and maintain low noise operation.

Additional Features

- A monitor photodiode can be reverse biased from 0–5V with no external power supply
- Preset output current or laser power level
- USB Interface
- Fully independent current limit

2.2 Specifications

	501B (Obsolete)	505B	525B (Obsolete)	560B
Output Current				
Output Current Range (mA)	0–50	0–100	0–200	0–6,000
Output Current Resolution (mA)	0.001	0.002	0.004	0.12
Output Current Accuracy (%FS)	±0.03	±0.05	±0.07	±0.09
Compliance Voltage (V)	7	7	7	5
Temperature Coefficient (ppm FS/°C)	<50	<50	<50	<50 <80
Short-Term Stability (1 h) (ppm FS)	<10	<10	<10	<20
Long-Term Stability (24 h) (ppm FS)	<50	<50	<50	<50
Noise/Ripple (rms) (µA)				
Hi BW	<0.7	<1	<1.5	<13.8
Lo BW	<0.1	<0.3	<1.1	<12
Current Limit				
Range (mA)	0–50.50	0–101.0	0–202.0	0–6,060
Resolution (mA)	0.001	0.002	0.004	0.12
Accuracy (%FS)	±0.03	±0.05	±0.07	±0.09
External Analog Modulation				
Input Range	0 to 10V; 10kΩ	0 to 10V; 10kΩ	0 to 10V; 10kΩ	0 to 10V; 10kΩ
Transfer Function (mA/V)	5	10	20	600
Bandwidth (kHz)				
External Modulation Bandwidth Hi BW	DC to 1000 ⁽¹⁾	DC to 600	DC to 660	DC to 100
External Modulation Bandwidth Lo BW	DC to 10	DC to 10	DC to 12	DC to 10
Photodiode Input				
Monitor Current Range (mA)	0–5	0–5	0–50	0–50
Monitor Current Stability (24 h) (%FS)	±0.02	±0.02	±0.02	±0.02
Monitor Current Accuracy (%FS)	±0.05	±0.05	±0.05	±0.05
Photodiode Bias Voltage (V)	0 to -5	0 to -5	0 to -5	0 to -5
Measurement Display				
Output Current Range (mA)	0–50.00	0–100.0	0–200.0	0–6000
Output Current Resolution (mA)	0.01	0.01	0.1	1.0
Output Current Accuracy (%FS)	±0.03	±0.05	±0.07	±0.09
Photodiode Current Range	0–5000µA	0–5000µA	0–50.00mA	0–50.00mA
Photodiode Current Resolution (µA)	1.0	1.0	10	10
Photodiode Current Accuracy (%FS)	±0.05	±0.05	±0.05	±0.05

⁽¹⁾ When 501B pin 3 (chassis) is connected to either anode or cathode the bandwidth may decrease to 700kHz.

Table 1 General Specifications

Environmental Specifications

Voltage Requirements	~100/120/220/240 VAC, 50/60Hz
Power Requirements	501B MAX POWER = 20W 505B MAX POWER = 30W 525B MAX POWER = 60W 560B MAX POWER = 90W
Chassis Ground	4 mm banana jack
Size (H x W x D) [in. (mm)]	3.5 (88) x 8.5 (215) x 12.6 (320)
Mainframe Weight [lb (kg)]	8.9 (4.05)
Operating Temperature	0°C to 40°C (<90% humidity non-condensing)
Storage Temperature	-40°C to + 70°C (<90% humidity non-condensing)
Relative Humidity, Storage	<90% humidity non-condensing
Altitude	<3000 meters (10000 feet)
Installation Category	II
Pollution Degree	2
Use Location	Indoor use only
Laser Safety Features	Output On/Off keyswitch, interlock, output delay (meets CDRH US21 CFR 1040.10)
Output Connectors Interlock/Photodiode	9-pin female D-sub
Output Connectors External Photodiode	BNC
Output Connectors Modulation	BNC

Table 2 Environmental Specifications

2.3 Accessories

The Model 500B Series Laser Diode Drivers come with a line cord for connection to AC power. To order accessories use the following part numbers:

<u>PART #</u>	<u>DESCRIPTION</u>
500-02	Laser Diode Driver Cable
500-04	Laser Diode Driver/Mount Cable
35-RACK	Rack Mount Kit

This page is intentionally left blank

3 Getting Started

3.1 Unpacking and Handling

It is recommended that the Model 500B Series Laser Diode Drivers be unpacked in a lab environment or work site. Unpack the system carefully; small parts and cables are included with the instrument. Inspect the box carefully for loose parts before disposing of the packaging. You are urged to save the packaging material in case you need to ship your equipment in the future.

3.2 Inspection for Damage

The Model 500B Series Laser Diode Drivers are carefully packaged at the factory to minimize the possibility of damage during shipping. Inspect the box for external signs of damage or mishandling. Inspect the contents for damage. If there is visible damage to the instrument upon receipt, inform the shipping company and Newport Corporation immediately.



WARNING

Do not attempt to operate this equipment if there is evidence of shipping damage or you suspect the unit is damaged. Damaged equipment may present additional hazards to you. Contact Newport technical support for advice before attempting to plug in and operate damaged equipment.

3.3 Available Options and Accessories

Model 500B Laser Diode Drivers:

501B	100mA Laser Diode Driver (Obsolete)
505B	500mA Laser Diode Driver
525B	2.5Amp Laser Diode Driver (Obsolete)
560B	6.0Amp Laser Diode Driver

Accessories:

500-02	Laser Diode Driver Cable
500-04	Laser Diode Driver/Mount Cable
35-RACK	Rack Mount Kit

Newport Corporation also supplies temperature controlled mounts, lenses, and other accessories. Please consult with your representative for additional information.

3.4 Parts List

The following is a list of parts included with the Model 500B Series Laser Diode Drivers:

1. User's manual (CD)
2. Power cord
3. Laser Diode Driver
4. Laser Diode Driver Cable (Optional)
5. Laser Diode Driver/Mount Cable (Optional)
6. Rack Mount Kit (Optional)
7. Certificate of Calibration

If you are missing any hardware or have questions about the hardware you have received, please contact Newport Corporation.

3.5 Choosing and Preparing a Suitable Work Surface

The Model 500B Series Laser Diode Drivers may be placed on any reasonably firm table or bench during operation. The front legs of the unit can be pulled out to tilt the unit at an angle, if desired.

3.6 Electrical Requirements

Before attempting to power up the unit for the first time, the following precautions must be followed:



WARNING

To avoid electric shock, connect the instrument to properly earth-grounded, 3-prong receptacles only. Failure to observe this precaution can result in severe injury.

- Have a qualified electrician verify the wall socket that will be used is properly polarized and properly grounded.
- Provide adequate distance between the Model 500B Series Laser Diode Drivers and adjacent walls for ventilation purposes. Approximately 2-inch spacing for all surfaces is adequate.
- Set the mains selector tumbler to the voltage that matches the power outlet AC voltage.

3.7 Power Supplies

- AC power is supplied through the rear panel input power connector which provides in-line transient protection and RF filtering. The input power connector contains the fuses and the switch to select series or parallel connection of the transformer primaries for operation at 100VAC, 120VAC, 220VAC or 240VAC

This page is intentionally left blank

4 System Operation



WARNING

Before operating the Model 500B Series Laser Diode Drivers, please read and understand all of Section 1.

4.1 Front Panel

The front panel of the Model 500B Series Laser Diode Driver is arranged for easy operation. Seven distinct areas, each with a specific set of related functions, and a control knob are located on the front panel, as shown in Figure 12 below.

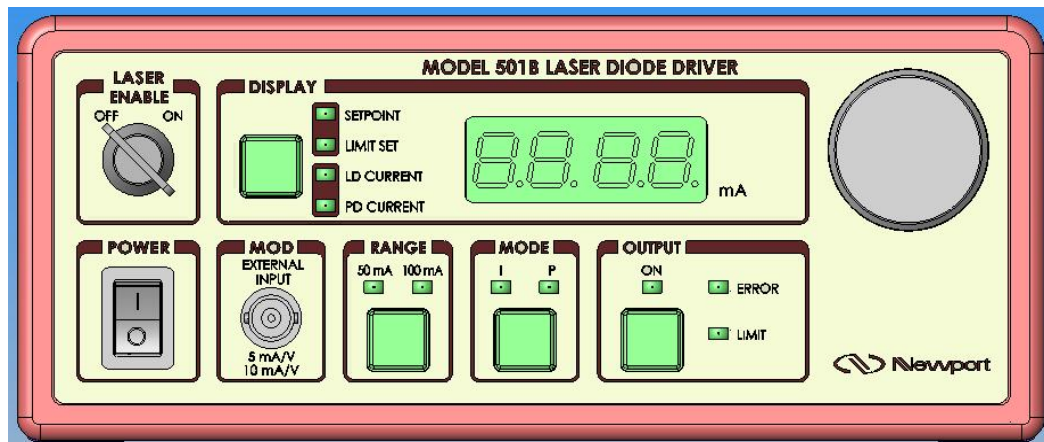

Figure 12

Front Panel Layout (501B shown)

4.1.1 AC Power Switch

When AC power is turned on the unit starts up in a default configuration with the OUTPUT off and the display in the SETPOINT mode. The power switch is located in the lower left corner of the instrument front panel.

4.1.2 MOD

Modulation of the laser diode by an external signal source through the MOD input BNC only available in the CURRENT mode. The output current level to the laser diode can be set using external voltage source or it can be modulated with a function generator signal. Any input modulation signal is added to the DC drive current level set by the front panel control knob. The

gain ranges noted below the BNC correspond to the low or high RANGE. A bandwidth selection switch on the back panel introduces a dampening filter in the output control loop to reduce the output noise when external modulation is not required. If the output drive current does not respond to a modulation frequency above 10kHz, check the switch to make sure it is not in the LOW bandwidth position.

4.1.3 Range Switch

Each Model 500B series unit has two output current ranges. Before turning the output on, the RANGE must be selected.

4.1.4 Mode Switch

The Model 500B Series Laser Diode Drivers have two modes of operation; constant current (I) and constant optical power (P). Mode selection can only be made when the OUTPUT is OFF.

In the “I” mode the output drive current to the laser diode is held at a constant level. The output of the laser diode can be modulated in this mode by connecting an external signal source to the MOD input on the front panel.

The Model 500B Series can be used with a monitor photodiode and can be operated in a constant optical power mode. Reverse voltage biasing of the photodiode is a standard feature that improves the dynamic range and frequency response of a laser diode. In the “P” mode the output current to the laser diode is controlled in response to the monitor photodiode current to maintain a constant output optical power. As a laser diode ages or the temperature of the laser diode increases more output drive current is required to maintain a constant optical power level. The output current LIMIT prevents the laser diode from exceeding its maximum current rating. The laser diode cannot be modulated in the POWER mode.

4.1.5 OUTPUT ON Switch and Indicator

The switch will activate the ON LED and allow current flow to the laser diode after an approximately 4 second delay. Current will not flow unless the laser diode is correctly connected, the “LASER ENABLE” key switch is activated, and pin 1 and 2 of the back panel interlock feature are shorted.

ERROR Indicator LED

The following conditions will cause the red ERROR LED and its protection circuitry to activate, automatically shutting off the output:

- a. An open circuit in the laser diode package or cabling.
- b. If the forward voltage drop of a laser diode (or series arrangements of multiple diodes) exceeds the compliance voltage specified in Table 1.
- c. Over-modulating the external voltage input to cause the laser output current to exceed the previously set limit value.
- d. Some external transient events that could damage the laser.

Once the fault is corrected, the OUTPUT ON switch must be pushed once to clear the error indication, and a second time to restore current to the laser diode.

LIMIT Indicator LED

A soft limit occurs when the output current gradually exceeds a preset value, clamping the current flow at that level and causing the LIMIT LED to blink until the threshold is no longer exceeded. A hard limit, indicated by a solid yellow LED and the ERROR LED will occur if the external input is over modulated when first attempting to turn on the output. The error must be cleared before normal operation can occur.

4.1.6 Laser Enable

This key switch is a safety feature that allows an OUTPUT about 4 seconds after being turned on. The key may only be removed in the OFF position.

4.1.7 Display Section

The display located in the top center of the front panel is a 4 digit green LED array. It reads current in mA for all Series 500B models. Pushing the switch repeatedly, cycles through display values as described below. Display modes can be toggled when the output is either ON or OFF.

SETPOINT Display

This mode allows setting diode current levels with the control knob before actually turning on the output. If constant current (I) mode is selected, the current setpoint corresponds to output laser diode current. If constant optical power (P) mode is selected, the current setpoint corresponds to monitor photodiode current.

LIMIT SET Display

This mode allows setting diode current limit level with the control knob.

LD CURRENT Display

This readout measures actual current flow in milli-Amps to the laser diode. The current level will drop to zero when the output is OFF. The display shows the average output drive current if the laser diode is modulated with a varying external input waveform.

PD CURRENT Display

Using the monitor photodiode current (I_m) displayed, a conversion table supplied by the diode manufacturer will indicate actual optical power level.

4.1.8 Control Knob

Located on the right side of the front panel, this knob is used to set the appropriate drive current when the display is in either SETPOINT or LIMIT SET modes.

4.2 Rear Panel

The Model 500B Series rear panel shows the OUTPUT connectors, a REMOTE/LOCAL switch, the photodiode reverse voltage BIAS ADJUST screw, a photodiode BNC input, the BANDWIDTH selection switch, and the AC power inlet.

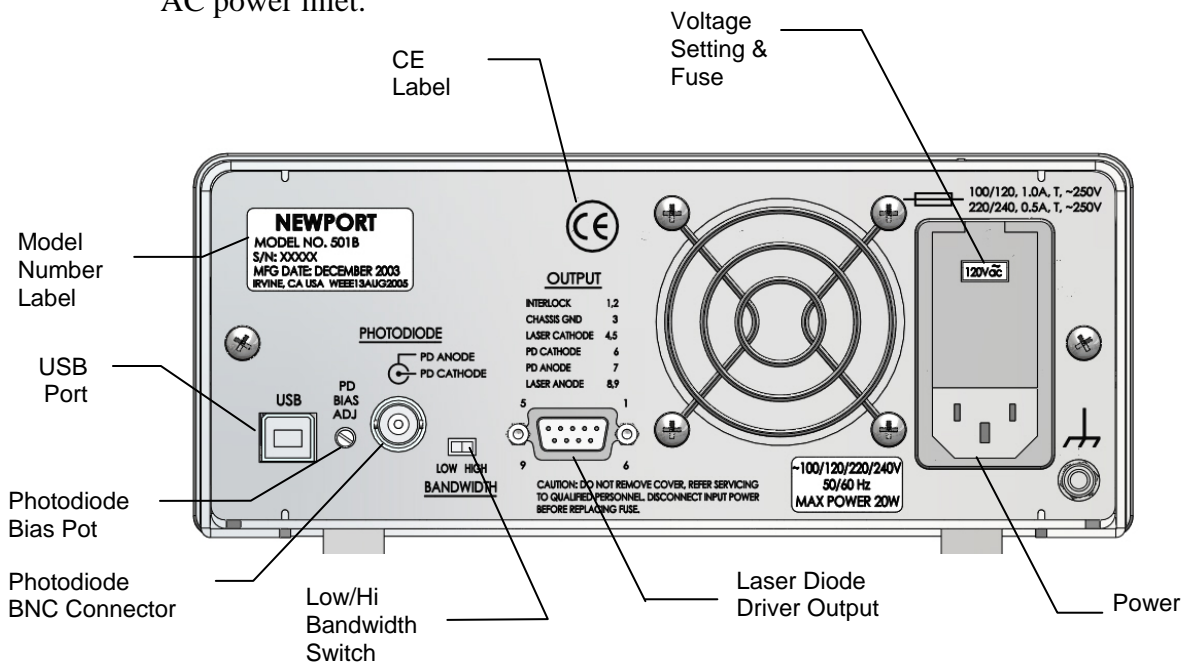

Figure 13

Rear Panel

4.2.1 USB Interface

The instrument is designed to communicate with standard USB interfaces. The cable required is a USB A/ B connection cable.

4.2.2 PD Bias Adjustment

A monitor photodiode may be reverse biased up to -5 volts using the PD BIAS adjustment screw. In the farthest clockwise position the photodiode is zero biased. Turning the screw counter-clockwise increases the bias voltage.

4.2.3 Bandwidth Select Switch

Setting the bandwidth select switch LOW dampens the output response, thereby reducing noise levels in the 0-10kHz modulation range. Modulation rates above 10kHz require a faster output response requiring the bandwidth selection switch to be set to the HIGH position. The maximum modulation frequency depends on the drive capabilities specified in Table 1.

4.2.4 Photodiode BNC Input

The photodiode input connector is used to attach a stand-alone photodiode. The BNC is connected in parallel with pin 6 (cathode) and pin 7 (anode) of the D-Sub 9 output connector. The center terminal of the BNC is the cathode, while the outside shell is the anode and is isolated from the chassis. PD bias adjustments are made with the (+) side of a DC voltmeter to cathode, and (-) side probe to anode (0 to +5VDC scale).

4.2.5 Output Connector

Connections to the laser diode and photodiode are made with a 9-pin, D-sub connector.

4.2.6 Output Connections

The pin connections to the laser diode and monitor photodiode are made from the 9-pin, D-sub connector labeled OUTPUT. The connections are printed on the rear panel and should be made as shown in Figure 17 and Figure 18.

Pin #	Description	Wire Color
1,2	Interlock	Shorting jumper or external closure
3	Chassis Gnd	AC coupled to chassis shield or drain wire
4,5	Laser Cathode	Black
6	Photodiode Cathode	White
7	Photodiode Anode	Green
8,9	Laser Anode	Red

4.2.7 Chassis GND

This 4 mm banana jack is connected to chassis ground. It's intended to be used as an additional earth ground connection for the Laser Diode Driver enclosure.

4.2.8 AC Power Inlet

The input voltage setting is indicated in a small window on the face of the power module. A small screwdriver is needed to flip down the panel once the AC line cord is removed. Carefully rotate the plastic tumbler and reinsert

it to show the appropriate power grid voltage. The fuse is also located behind this panel and can be pulled out, for replacement with the appropriate size, as indicated on the back panel.

All units are preset at the factory for operation at 108-132VAC, 60HZ.

The fuse must be changed for 198-242VAC and 216-264VAC operation.

Select

- 100VAC for operation at 90-110VAC, 60Hz
- 120VAC for operation at 108-132VAC, 60Hz
- 220VAC for operation at 198-242VAC, 50Hz
- 240VAC for operation at 216-264VAC, 50Hz

The line cord supplied with each unit should be plugged only into a properly grounded three-prong outlet to prevent electrical shock in the event of an internal short circuit to the metal cabinet.

4.2.9 Frame or Chassis Terminal

This terminal provides access to frame or chassis connection.

4.2.10 Power Inlet Socket

Plug the included power cord into the Power Inlet Socket on the rear of the instrument, then plug the power cord into a wall socket with proper earth grounding.

5 Computer Interfacing

5.1 Memory

The calibration constants and other laser parameters that must be retained even when the power is removed from the unit, are stored in an electrically erasable programmable memory (EEROM).

5.2 Interlock Operation

The back panel laser input/output connector has interlock connections that must be connected before the laser output will be enabled.

5.3 Commands and Queries

There are two types of device commands: commands that cause the instrument to take a desired action, and queries that return a stored value or state of the instrument. Queries must end with a question mark (?), while commands may require parameter(s) to follow:

LASer:LIMit:I 50.00

For example, the value “50.00” in the command **LASer:LIMit:I 50.00**, sets the laser current limit at 50.00. Table 3 below summarizes all the commands and queries supported by the instrument. The command/query **MUST** contain all of the letters that the commands are optional, and may be used for clarity.

The commands may be sent to the instrument in either upper or lower case or in any combination. For example, the following commands are equal:

LASer:LIMit:I 50.00

LAS:LIM:I 50.00

las:LIM:I 50.00

Las:Lim:I 50.00

COMMAND EXECUTION:

The controller interprets the commands in the order they are received and execute them sequentially. If a set of commands have to be executed closer to each other, these commands can be sent to the controller simultaneously by creating a command string with semicolon (;) used as a command separator. The command string length should not exceed 50 characters. In the example shown below, a command string was created with semicolon separating 5 queries. The controller responds to this command string with a response that has 5 values using a comma (,) as a separator.

COMMAND STRING:

LAS:OUT?;LAS:SET:I?;LAS:I?;LAS:SET:MDI?;LAS:MDI?

INSTRUMENT RESPONSE:

0,5540,0,33.94,0.00

COMMAND TERMINATION:

All commands sent to the instrument must be terminated by <Carriage Return><Line Feed>.characters. All responses sent out by the instrument are terminated by the same characters.

NOTE

For compatibility, some commands have optional entries; such as **LASer:LDI**, which can also be **LASer:I**. Options are shown in Table 3 as parenthesis; such as **LASer:LDI (I)**. After Table 3, each command and query is detailed.

Commands common to both Temperature Controllers and Laser Diode Drivers:

Command Syntax	Command Description	Remarks
*CLS	Clear status and response buffer command	
*IDN?	Identification Query	
*RCL	Recall Settings	Restore instrument to setup state stored in its non-volatile local memory
*RST	Reset Instrument	
*SAV	Save Settings	Save instrument's current settings in its non-volatile local memory
*STB?	Status Byte Query	Returns "message available" and "error message available" status
ADDRess	Address Command	Sets the controller USB address
ADDRess?	Address Query	Returns the controller's USB address
ERRors?	Error query	Returns error code
ERRSTR?	Error string query	Returns error string
LOCAL	Return to local mode	Makes front panel buttons active
HWTemp?	Temperature query	Returns instrument temperature in deg. C
KEYswitch?	Key switch query	Returns key switch ON / OFF status

Commands specific to Laser Diode Drivers

Command Syntax	Command Description	Remarks
LASer:LDI(I)	Laser current set point	
LASer:SET:LDI? (I?)	Laser current set point query	
LASer:LDI? (I?)	Measured laser current query	
LASer:MDI(IPD)	Laser photodiode current set point	
LASer:SET:MDI? (IPDI)	Laser photodiode current set point query	
LASer:MDI? (IPD?)	Measured laser photodiode current query	
LASer:LDV?	Measured forward voltage query	Same as compliance voltage
LASer:LIMit:LDI(I)	Laser current limit set	
LASer:LIMit:LDI?(I?)	Laser current limit set query	
LASer:MODE?	Laser mode query	
LASer:MODE:I (ILBW, IHBW)	Constant laser current mode	
LASer:MODE:MDI(IPD)	Constant photodiode current mode	
LASer:MODE:BWidth?	Bandwidth switch setting query	
LASer:OUTput	Laser output enable/disable	
LASer:OUTput?	Laser output enable status query	
LASer:RANGE	Laser current range	
LASer:RANGE?	Laser current range query	

Table 3

Command Summary

***CLS**

Description Clear status and response buffer command

Syntax *CLS

Remarks The *CLS command is used to clear the status byte register and the response buffer. This command may be issued if query commands and their responses fall out of sync with each other.

See Also *STB?

***IDN?**

Description Identification query.

Syntax *IDN?

Remarks This query will cause the instrument to return an identification string.

Model name	Firmware version #	Firmware date	Controller Serial #
XXXX	vYYY	mm/dd/yy	SNZZZZ

NEWPORT

***RCL**

Description Recall command.

Syntax *RCL value

Argument	Value	Description
<i>Value</i>	0	Restores Factory Default settings
	1	Restores last saved working setting
	2	Restores last saved user settings

Remarks The recall command restores the instrument to the setup state which was last saved using *SAV Command.

See Also *RST, *SAV

***RST**

Description Reset command.

Syntax *RST

Remarks The reset command performs a device reset.

See Also *RCL

SAV*Description** Save command.**Syntax** *SAV value

Argument	Value	Description
<i>Value</i>	0	Not used
	1	Saves current settings to working settings
	2	Saves current settings to user settings

Remarks The save command stores the current state of the instrument in non-volatile local memory. This state is then recalled by using the *RCL recall command.**See Also** *RCL

STB?*Description** Status Byte Register query.**Syntax** *STB?**Remarks** The Read Status Back query allows the programmer to read the Status Byte Register.

Response	Description
<i>Status Byte Register</i>	bit 0 Reserved
	bit 1 Reserved
	bit 2 Reserved
	bit 3 Reserved
	bit 4 Message Available
	bit 5 Reserved
	bit 6 Reserved
	bit 7 Error Message Available

ADDRESS**Description** USB address command.**Syntax** ADDRESS value**Remarks** The ADDRESS command sets the instrument USB address. After changing USB address, the communication with the instrument has to be re-initialized. This can be accomplished by calling "InitSystem" function in the DLL available in the CD provided with the instrument.

Argument	Value	Description
<i>Value</i>	0	Reserved
	1 to 99	Valid USB address range

See Also ADDRESS?

ADDRess?

Description USB address query.

Syntax ADDRess?

Remarks The ADDRess query returns the controller's USB address.

Response	Value	Description
<i>address</i>	0	<i>Reserved</i>
	1 to 99	<i>Valid USB address range</i>

See Also ADDRess

ERRors?

Description Error query.

Syntax ERRors?

Remarks The ERRors? query returns a list of commands and device errors which have occurred since the last query. These errors are indicated by a number that corresponds to the type of error which occurred.

Response	Description
<i>Error code</i>	Error code number, 0 if no errors

See Also ERRSTR?

Error Messages

0 NO ERROR

No errors exist in the output buffer.

099 FIRMWARE NOT VALID

The previous firmware update was not completed successfully. Update the firmware again.

115 IDENTIFIER NOT VALID

The issued command does not exist. Check the command syntax.

200 REMOTE MODE

Instrument is presently in remote mode. As a result, the rotary knob and "RANGE", "MODE" and "OUTPUT" switches have been made inactive. Issue "LOCAL" command to make the knob and switches active.

201 VALUE OUT OF RANGE

The specified parameter is out of range. Refer to the description of issued command for valid parameter range.

501 INTERLOCK ERROR

The output has been turned OFF because interlock has been disconnected from rear panel (DB9 pins 1,2).

502 HARD CURRENT LIMIT ERROR

The output has been turned OFF because:

- a. An open circuit in the laser diode package or cabling.
- b. Overmodulating the external voltage input caused the laser output current to exceed a previously set limit value.

Once the fault is corrected, “LAS:OUTput 1” command must be issued once to clear the error indication, and a second time to restore current to the laser diode.

505 COMP VOLTAGE LIMIT ERROR

The output has been turned OFF because the forward voltage drop of a laser diode (or series arrangements of multiple diodes) exceeds the compliance voltage specified in Table 1. Once the fault is corrected, “LAS:OUTput 1” command must be issued once to clear the error indication, and a second time to restore current to the laser diode.

513 RANGE CHANGE

The output has been turned OFF because a range change was commanded using “LAS:RANGE” command.

514 MODE CHANGE

The output has been turned OFF because a mode change was commanded using either “LAS:MODE:I” or “LAS:MODE:MDI” command.

901 SYSTEM OVER TEMPERATURE ERROR

The output has been turned OFF because temperature inside the instrument has exceeded 75 degC. Once the fault is corrected, “LAS:OUTput 1” command must be issued once to clear the error indication, and a second time to restore current to the laser diode.

902 LASER ENABLE OFF

The output has been turned OFF because front panel key switch (LASER ENABLE) is in OFF position.

ERRSTR?

Description Error string query.

Syntax **ERRSTR?**

Remarks The **ERRSTR?** query returns a list of commands and device error numbers along with the corresponding error text strings which have occurred since the last query.

Response	Description
<i>Error code, “text”</i>	Error code and text for error code as per chapter, 0 if no errors

See Also **ERRors?**

LOCAL

Description Return to local mode (from USB remote)

Syntax **LOCAL**

Remarks Returns the controller to local mode after being placed in remote mode by the USB interface.

KEYswitch?

Description Key switch setting query

Syntax **KEYswitch?**

Remarks The **KEYswitch** query returns an integer that indicates the present state of front panel key switch.

Response	Value	Description
<i>Status</i>	<i>0</i>	<i>OFF</i>
	<i>1</i>	<i>ON</i>

HWTemp?

Description Hardware (chassis) temperature query.

Syntax **HWTemp?**

Remarks The **HWTemp?** query returns the value of the hardware temperature measurement.

Response	Description
<i>measured temp</i>	Measured temperature in °C

This measurement is updated approximately once every 225 milliseconds.

LASer:LDI (I)

Description Laser current set point command.

Syntax **LASer:LDI** *current set point*

Remarks Sets the laser's constant current set point.

Argument	Description
<i>current set point</i>	Laser driver output in mA

This command will not affect the output if the channel is in IPD or MDI modes.

See Also **LASer:LDI?**, **LASer:SET:LDI?**

LASer:SET:LDI? (I?)

Description Laser constant current set point query.

Syntax **LASer:SET:LDI?**

Remarks The **LASer:SET:LDI?** query returns the constant current set point.

Response	Description
<i>current set point</i>	Current set point in mA

See Also **LASer:LDI**

LASer:LDI? (I?)

Description Measured laser current query.

Syntax **LASer:LDI?**

Remarks The **LASer:LDI?** query returns the value of the measured laser current.

Response	Description
<i>measured current</i>	Measured laser current in mA

This measurement is updated approximately once every 225 milliseconds.

See Also **LASer:LDI, LASer:SET:LDI?**

LASer:MDI (IPD)

Description Laser photodiode current set point command.

Syntax **LASer:MDI** *photodiode current*

Remarks The **LASer:MDI** command sets the value of the photodiode current set point, in mA.

Argument	Description
<i>photodiode current</i>	Photodiode current set point in mA

See Also **LASer:MDI?, LASer:SET:MDI?**

LASer:SET:MDI? (IPD?)

Description Laser constant photodiode current set point query.

Syntax **LASer:SET:MDI?**

Remarks The **LASer:SET:MDI?** query returns the laser photodiode current set point value in mA.

Response	Description
<i>PD current set point</i>	Photodiode current set point in mA

See Also **LASer:MDI**

LASer:MDI? (IPD?)

Description Laser measured photodiode current query.

Syntax **LASer:MDI?**

Remarks The **LASer:MDI** query returns the value of the measured photodiode current.

Response	Description
<i>measured PD current</i>	Measured photodiode current in mA

This measurement is updated approximately once every 225 milliseconds.

See Also **LASer:MDI, LASer:SET:MDI?**

LASer:LDV?

Description Measured forward voltage query.

Syntax **LASer:LDV?**

Remarks The **LASer:LDV?** query returns the laser channel's measured forward voltage.

Response	Description
<i>measured voltage</i>	Laser diode forward voltage in volts

LASer:LIMit:LDI (I)

Description Laser current limit set command.

Syntax **LASer:LIMit:LDI** *current limit*

Remarks The **LASer:LIMit:LDI** command sets the laser current limit value.

Argument	Description
<i>current limit</i>	Current limit in mA

See Also **LASer:LIMit:LDI?**

LASer:LIMit:LDI? (I?)

Description Laser current limit set query.

Syntax **LASer:LIMit:LDI?**

Remarks The **LASer:LIMit:LDI?** query returns the value of the laser current limit.

Response	Description
<i>current limit</i>	Current limit in mA

See Also **LASer:LIMit:LDI**

LASer:MODE?

- Description** Laser mode query.
- Syntax** LASer:MODE?
- Remarks** The LASer:MODE? query returns the selected laser control mode.

Response	Value	Description
<i>mode</i>	"Ilbw"	constant current mode, low bandwidth
	"Ihbw"	constant current mode, high bandwidth
	"Mdi"	constant power mode

- See Also** LASer:MODE:ILBW, LASer:MODE:IHBW, LASer:MODE:ICW, LASer:MODE:MDI, LASer:MODE:P

LASer:MODE:I (ILBW, IHBW)

- Description** Enter constant current mode command.
- Syntax** LASer:MODE:I
- Remarks** The LASer:MODE:I command selects the laser constant current mode. If this command is issued when the output is ON, output is turned OFF, and the mode is set to constant current mode.
- See Also** LASer:MODE?

LASer:MODE:MDI (IPD)

- Description** Enter constant photodiode current mode command.
- Syntax** LASer:MODE:MDI
- Remarks** The LASer:MODE:MDI command selects the photodiode constant current mode. If this command is issued when the output is ON, output is turned OFF, and the mode is set to constant photodiode current mode.
- See Also** LASer:MODE?

LASer:MODE:BWidth?

- Description** Bandwidth switch setting query
- Syntax** LASer:MODE: BWidth?
- Remarks** The LASer:MODE: BWidth query returns an integer that indicates the present Bandwidth switch setting.

Response	Value	Description
<i>Status</i>	0	<i>Low</i>
	1	<i>High</i>

LASer:OUTput

Description Laser enable output command.

Syntax **LASer:OUTput** *enable*

Remarks The **LASer:OUTput** command turns the laser output on or off.

Argument	Value	Description
<i>enable</i>	0	off
	1	on

When the laser output is off, an internal short is placed across the output terminals.

See Also **LASer:OUTput?**

LASer:OUTput?

Description Laser enable output query.

Syntax **LASer:OUTput?**

Remarks The **LASer:OUTput?** query returns the status of the laser output.

Response	Value	Description
<i>enable</i>	0	off
	1	on

See Also **LASer:OUTput**

LASer:RANGE

Description Range select.

Syntax **LASer:RANGE** *range*

Remarks Each Model 500B series unit has two output current ranges. If this command is issued when the output is ON, output is turned OFF, and the range is set to the desired state.

Response	Value	Description
<i>Status</i>	0	<i>Low</i>
	1	<i>High</i>

See Also **LASer:RANGE?**

LASer:RANGE?

Description Range query

Syntax LASer:RANGE range?

Remarks The LASer:RANGE query returns an integer that indicates the present range

Response	Value	Description
<i>Status</i>	<i>0</i>	<i>Low</i>
	<i>1</i>	<i>High</i>

See Also LASer:RANGE

This page is intentionally left blank

6 Software Application

6.1 Overview

The 300B/500B Controllers have a USB 2.0 connector on the back of the unit that is used to connect to a computer. This connector will work with USB 1.0 and 1.1 also, as it is fully backwards compatible.

Provided on the CD that comes with the unit is an installation for a software application that communicates with the 300B/500B using the USB port. The installation installs the USB drivers that are required to use USB communication.

The design of the software is to allow the user to remotely control the functions of the instrument.

6.2 Connection

Select either the LDD or TEC page tab. Set the USB (Virtual) Address and click the CONNECT button to start communicating with the instrument.

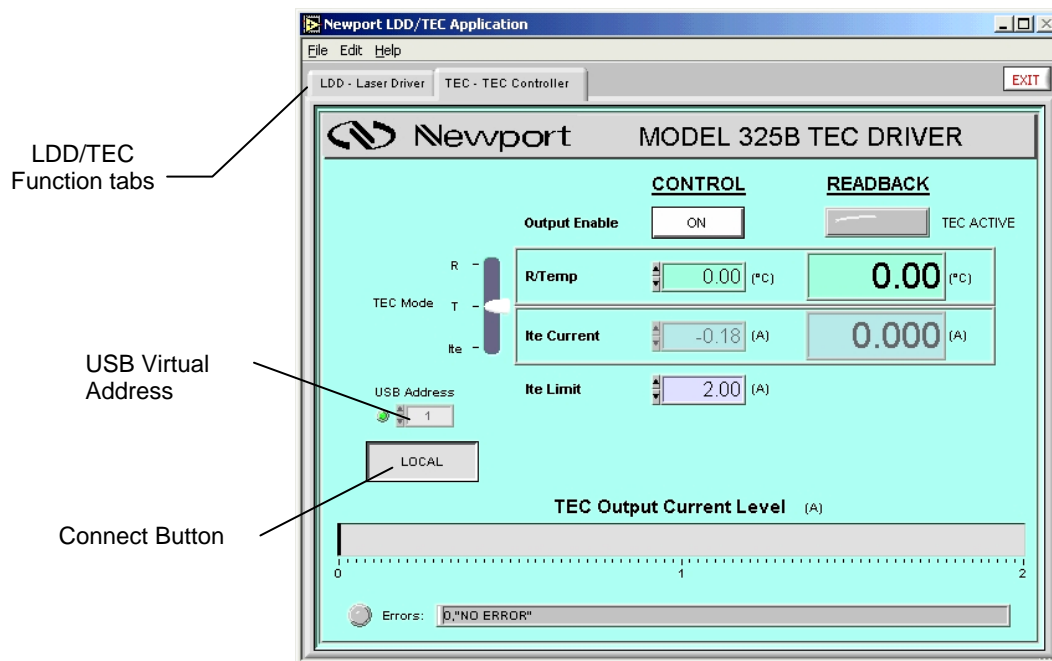

Figure 14

Application front panel (TEC Tab)

6.3 General Usage

This software application allows the user to setup and monitor the instrument remotely.

The controls on the instrument are available in the software in a very easy to read and change format.

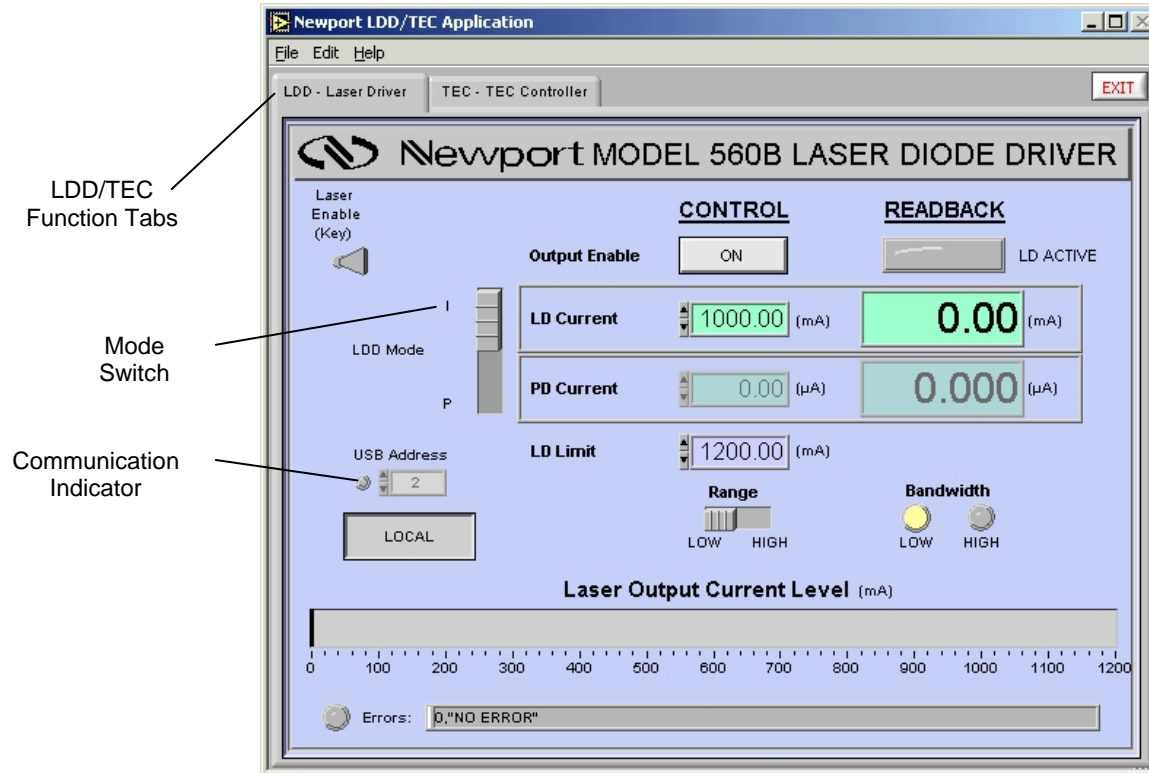

Figure 15

Application front panel when communicating (LDD Tab)

The software has two tabs, one for the (300B) TEC specific functions, and one for the (500B) LDD functions. The individual TEC and LDD specific tabs have two columns labeled on the top as CONTROLS and READBACK.

6.3.1 LDD Tab

CONTROLS:

- | | |
|---------------|---|
| LDD Mode | - Sets I/P mode of control |
| Output Enable | - Turns on/off the output |
| LD Current | - Sets the forward laser current |
| PD Current | - Sets the monitor diode (PD) current |
| LD Limit | - Set the maximum limit for forward current |
| Range | - Set the operating range - Low/High |

READBACK:

- Output Enable - Displays output on/off state
- LD Current - Displays the forward laser current
- PD Current - Displays the monitor diode (PD) current
- Bandwidth - Displays the current bandwidth setting

6.3.2 TEC Tab

CONTROLS:

- TEC Mode - Sets R/T/I mode of control
- Output Enable - Turns on/off the output
- Temp/R - Sets the Temperature or Resistive setpoint
- ITE - Sets TEC Current
- ITE Limit - Set the maximum limit for TEC current

READBACK:

- Output Enable - Displays output on/off state
- Temp/R - Displays the Temperature or Resistance
- ITE - Displays the TEC Current

The Laser/TEC Output Current Level display on the bottom is a visual indicator of the current read-back, with the upper limit for that setpoint.

On the very bottom are an Error indicator light and a display of the last Errors, if any.

6.4 Menu Structure

To Exit the application, go to the File menu and select Exit.

The Edit/TEC Settings menu option has additional TEC settings such as PID gain settings.

The Edit/Advanced Properties menu option has additional property settings, including search for instruments and data logging options.

The File/Print will print the window.

The Help/About will show information about the application.

This page is intentionally left blank

7 Principles of Operation

7.1 Introduction

Operating procedures of the Model 500B Series Laser Diode Drivers include safe handling procedures for laser diodes, various types of laser diode packages, how to make the connections, and how to ground a laser diode.

7.2 Laser Diode Handling Precautions

Laser diodes are extremely sensitive to static discharge and guidelines should be followed at all times when handling laser diodes:

- a. All operators must have a properly grounded wrist strap before handling any laser diode.
- b. All soldering iron tips must be properly grounded.
- c. All related test and assembly equipment must be properly grounded

Laser diodes are extremely sensitive to electrostatic discharge since they can only withstand a maximum reverse voltage of 2 to 3V across their leads and no more than the maximum rated current in the forward direction.

NOTE

Always follow the manufacturer's instructions for removing and handling laser diodes.

NOTE

Always follow the laser diode manufacturer's specifications for maximum temperatures and soldering times.

Additional precaution must be taken when soldering leads of a laser diode. Excess heat from soldering damages the laser facet. Care must be taken to provide a heat sink between the laser diode and the leads during soldering.

Added protection from electrostatic discharge (ESD) can be obtained by inserting ferrite beads and capacitors near the laser diode as shown in Figure 16. When applying high-speed modulation to the laser diode, this circuit might reduce the maximum modulation frequency.

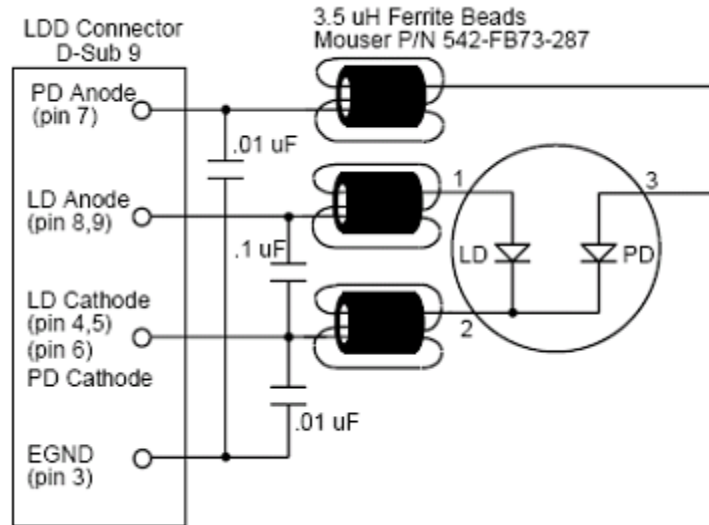

Figure 16

Laser Diode Protection Circuit.

7.3 Laser Diode Connections

Laser diodes come in many different types of packages, with and without monitor photodiodes. The following sections will show how to make connections to standard 9mm and 5.6mm packaged laser diodes and also telecommunication laser diodes in Dual In-Line (DIL) and butterfly packages. Any other packages such as TO-3 packages have laser diode and photodiode connections identical to the types shown below.

7.3.1 9mm and 5.6mm Laser Diode Packages

Almost all CD type packages fall into one of seven configurations as shown in Figure 17. Figure 18 shows how to connect a Model 500B Laser Diode Driver to three of the various laser diode and photodiode configurations.

NOTE

The optional chassis ground (earth ground) should not be connected until reading Sections 3 and 4.

Pin assignment from pin side		9mm & 5.6 mm Laser Diode Pin Connections			
		Pin 1	Pin 2	Pin 3	Pin 4
TYPE A		LD Cathode	PD Anode	LD Anode, PD Cathode, Case Common	
TYPE B		LD Anode	PD Anode	LD Cathode, PD Cathode, Case Common	
TYPE C		LD Anode	PD Cathode	LD Cathode, PD Anode, Case Common	
TYPE D		LD Cathode	PD Anode	PD Cathode	LD Anode, Case Common
TYPE E		LD Cathode	PD Anode	LD Anode, Case Common	PD Cathode
TYPE F		PD Anode	LD Cathode	PD Cathode, Case Common	LD Anode
TYPE G		LD Cathode	LD Anode, PD Cathode, Case Common	PD Anode	

Figure 17

Laser Diode/Photodiode package types with pin assignments.

NOTE

Pin assignments for some laser diodes may differ from those shown. Please be careful and check for the correct laser diode type before making any connections to a Model 500B Series Laser Diode Driver. If the laser diode is to be earth grounded, the CHASSIS GND pin 3 from the laser diode driver output connector is used to make this connection, which is connected internally to the chassis directly. Make sure that this is the only earth ground connection to the laser diode.

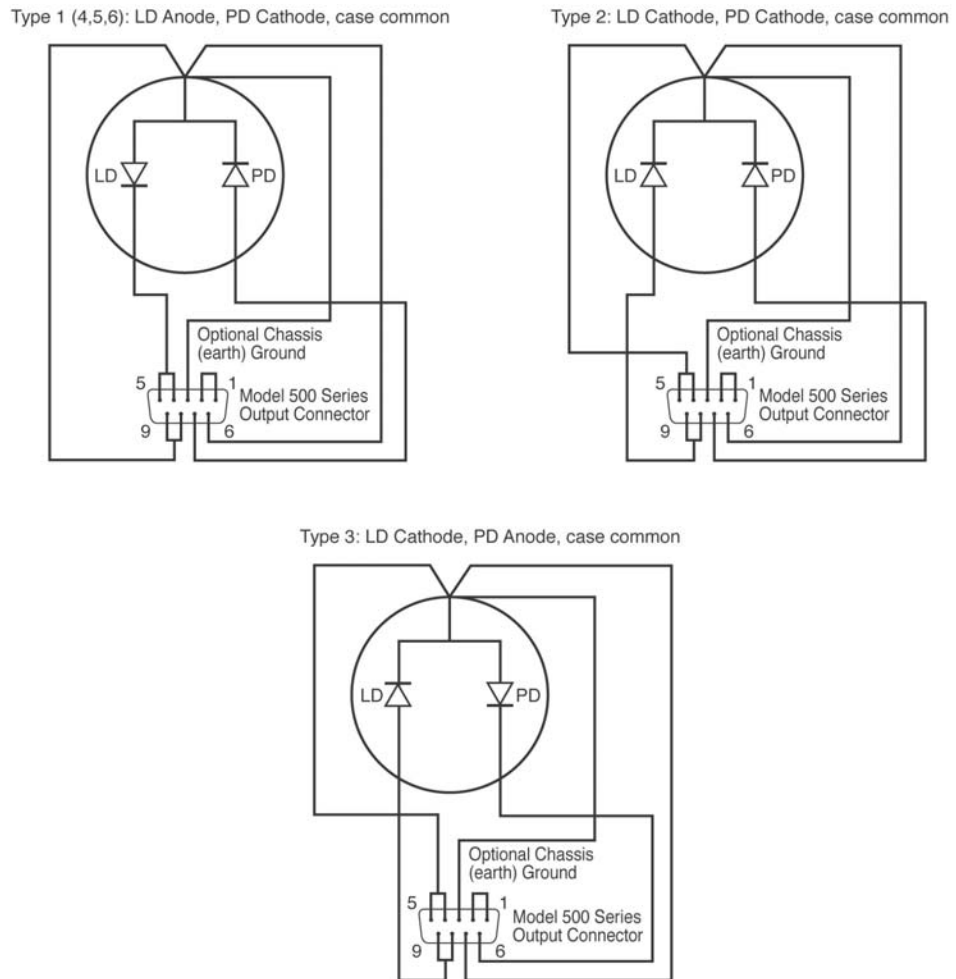

Figure 18

Laser Diode/Photodiode configurations and connections to 500B Series LDDs.

7.3.2 Telecommunication Laser Diode Packages

Most telecommunication laser packages fall into one of the following three configurations. Connections of a Model 500/B and Model 300/B unit to a

telecommunication laser package are shown in Figure 19. Care must be taken when connecting the chassis ground (earth ground) to the package.

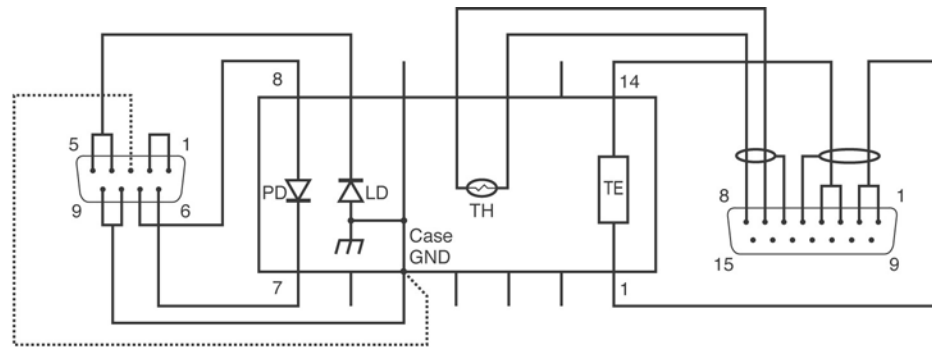

TYPE "A"
Lasertron (DIL)
Mitsubishi (DIL)
BT&D (DIL)

TE: Thermo-Electric Cooler
TH: Thermistor

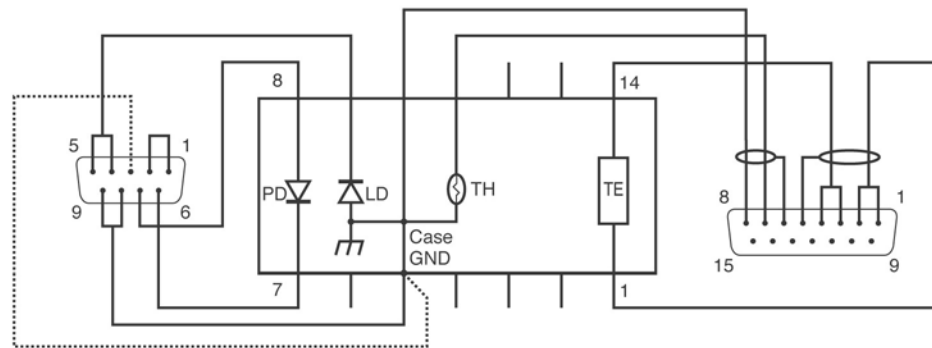

TYPE "B"
Alcatel (DIL)
Toshiba (Butterfly)
OKI (DIL)

TE: Thermo-Electric Cooler
TH: Thermistor

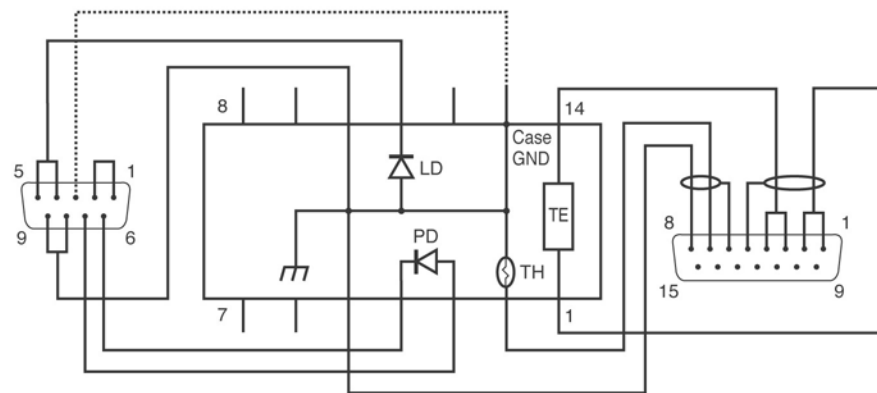

TYPE "C"
AT&T (Butterfly)
Lasertron (Butterfly)
Mitsubishi (Butterfly)

TE: Thermo-Electric Cooler
TH: Thermistor

Figure 19

Telecommunication laser diode packages and connections to 500B Series LDDs.

7.4 Grounding the Laser Diode

The outputs of the Model 500B Series are isolated from earth (chassis) ground. Isolating the laser diode case avoids damaging the device from multiple ground loop potentials, AC transients or static discharge. It is strongly recommended that a single point ground scheme be established, specifically at pin 3 of the DB-9 connector. This will help minimize noise, transients, and ground loop hazards. Pin 3 is connected directly to chassis. This ensures higher spectrum noise and electrostatic discharges being directed to ground while avoiding a direct galvanic connection between the laser diode and chassis.

If you have additional questions about your earth grounding method contact a Newport Corporation applications engineer.

7.5 Model 500B Series Setup

7.5.1 Using the Interlock Feature

The interlock feature is an additional contact closure in series with the front panel keyswitch. The loop between pins 1 and 2 can be removed as a relay contact or safety switch that disables the output drive circuit when opened. When the interlock loop is closed again, pushing the front panel OUTPUT switch will resume current flow after an approximately 4 second soft-start sequence. The switch or relay contact should be electrically isolated from all other circuits and earth ground.

7.5.2 Rack Mounting Model 500B Series Units

Two units, either Model 300B's or Model 500B's or one of each, may be mounted side by side in the standard rack mount kit (part 35-RACK). Remove the four feet on the bottom of the instrument. Use the screws supplied with the rack mount kit and secure the bottom of the unit(s) to the bracket using the two original front feet mounting positions. After tightening the screws the unit(s) may be slid into a 19" rack and secured to the side rails.

7.5.3 Model 500B Series Operation Checklist

The following step-by-step procedure should be followed when operating a Model 500B Series Laser Diode Driver:

- a. Check the AC voltage selection of the unit to be sure that it is compatible with the outlet to be used. All units are factory preset for operation from 108-132VAC, 60Hz. Fuses must be changed as indicated on the rear panel for 220VAC and 240VAC operation.
- b. Verify that the interlock feature has been enabled. Pins 1 and 2 of the OUTPUT connector must be shorted before the unit will allow the output current to flow to the laser diode.

-
- c. Connect the USB interface to a computer when remote operation is necessary
 - d. Turn the unit on and allow it to warm up.
 - e. Select RANGE of operation.
 - f. Set the LIMIT set point using the front panel control knob.
 - g. Connect the laser diode and photodiode.
 - h. Adjust the PD BIAS voltage to the photodiode.
 - i. Select either CURRENT or POWER mode.
 - j. Select SETPOINT display mode and set output current or monitor photodiode (optical power) level using the front panel control knob.
 - k. Enable KEYSWITCH, push OUTPUT on Switch, then toggle front panel display to the appropriate readout.

NOTE

Newport Corporation is not in any way responsible for any damage to any device used in conjunction with the Model 500B Series products.

This page is intentionally left blank

8 Maintenance and Service



CAUTION

There are no user serviceable parts inside the Model 500B Series Laser Diode Drivers. Work performed by persons not authorized by Newport Corporation will void the warranty.

8.1 Enclosure Cleaning



WARNING

Before cleaning the enclosure of the Model 500B Series Laser Diode Drivers, the AC power cord must be disconnected from the wall socket.

The source enclosure should only be cleaned with a mild soapy water solution applied to a damp lint-free cloth. Do not use an acetone or alcohol solution; this will damage the finish of the enclosure.

8.2 Fuse Replacement

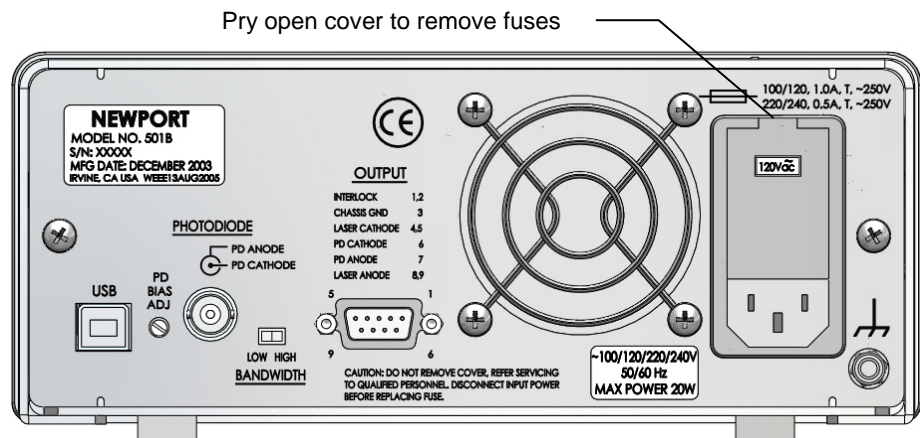

Figure 20

Fuse Replacement



WARNING

To reduce the risk of electric shock or damage to the instrument, turn the power switch off and disconnect the power cord before replacing a fuse.

If a fuse blows:

1. Disconnect the power cord from the controller
2. Pry out the fuse cover and remove the fuse holders.
3. Replace the fuse(s).

Use only Slo-Blo fuses as indicated below

<u>Fuse Replacement</u>	<u>Line Voltage</u>
1Amp, (T), 250V	100/120VAC
0.5Amp, (T), 250V	220/240VAC

4. Reconnect the power cord and turn on the instrument.
5. If the problem persists, contact Newport Corporation for service.

8.3 Obtaining Service

The Model 500B Series Laser Diode Driver contains no user serviceable parts. To obtain information regarding factory service, contact Newport Corporation or your Newport representative. Please have the following information available:

1. Instrument model number (on the rear panel)
2. Instrument serial number (on rear panel)
3. Description of the problem.

If the instrument is to be returned to Newport Corporation, you will be given a Return Number, which you should reference in your shipping documents. Please fill out a copy of the service form, located on the following page, and have the information ready when contacting Newport Corporation. Return the completed service form with the instrument.

8.4 Service Form



Newport®
Experience | Solutions

Newport Corporation
U.S.A. Office: 800-222-6440
FAX: 949/253-1479

Name _____ **Return Authorization #** _____
(Please obtain RA# prior to return of item)

Company _____
(Please obtain RA # prior to return of item)

Address _____ Date _____

Country _____ Phone Number _____

P.O. Number _____ FAX Number _____

Item(s) Being Returned:

Model # _____ Serial # _____

Description _____

Reason for return of goods (please list any specific problems):

**Newport Corporation
Worldwide Headquarters**

1791 Deere Avenue
Irvine, CA 92606

(In U.S.): 800-222-6440
Tel: 949-863-3144
Fax: 949-253-1680

Internet: sales@newport.com



Newport®

Experience | Solutions

Visit Newport Online at: www.newport.com