

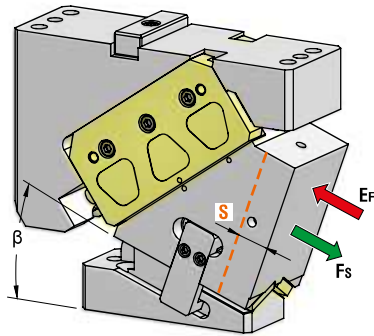

AERIAL CAM UNIT - OBEN HÄNGENDER SCHIEBER - UNITÀ A CAMME SOSPESA



OMCR CODE	Work Angle	Stroke (mm)	Max Work Force with shoulder (kN)	Extraction Force (kN)
	β	S	Fs	Ef Gas Spring
CHV085.00	0°	30,85	230	10,0
CHV085.05	5°	34,07	230	10,0
CHV085.10	10°	34,46	230	10,5
CHV085.15	15°	38,07	230	10,5
CHV085.20	20°	41,84	230	10,5
CHV085.25	25°	43,38	229	11,0
CHV085.30	30°	48	229	11,0
CHV085.35	35°	50,75	229	11,4
CHV085.40	40°	56,79	237	11,4
CHV085.45	45°	42,30	245	11,5
CHV085.50	50°	48,24	253	11,5
CHV085.55	55°	54,06	261	11,8
CHV085.60	60°	63,75	269	11,8
CHV085.65	65°	75,42	277	11,9
CHV085.70	70°	95,02	285	11,9
CHV085.75	75°	95,13	293	12,0



Art.	Work Angle = 5°
CHV085	05

OMCR CODE	Work Angle	Overall Dimensions (mm)											
	β	A	B	C	D	E	F	G	H	I	J	K	L
CHV085.00	0°	238	60	55	230	175	35	90	25	130	225	82	255
CHV085.05	5°	243,28	64,18	55	225	170	35	90	25	130	225	88	255
CHV085.10	10°	247,73	73,75	55	215	160	35	90	25	130	225	88	255
CHV085.15	15°	252,64	78,77	55	210	155	35	90	25	130	225	97	255
CHV085.20	20°	259,24	79,51	55	210	155	35	90	25	130	225	103	255
CHV085.25	25°	262,37	90,08	40	195	155	35	90	25	130	255	103	285
CHV085.30	30°	272,11	87,71	40	195	155	35	90	25	130	255	112	285
CHV085.35	35°	277,45	94,87	40	195	155	35	90	25	130	255	112	285
CHV085.40	40°	282,59	102,49	40	195	155	35	90	25	130	255	122,5	285
CHV085.45	45°	248,94	114,09	0	150	150	35	70	25	110	235	92	265
CHV085.50	50°	247,12	127,38	0	135	135	35	70	25	110	235	96,5	265
CHV085.55	55°	263	126,74	0	135	135	35	70	25	110	235	96,5	265
CHV085.60	60°	267,02	136,11	0	135	135	35	70	25	110	235	104	265
CHV085.65	65°	257,06	147,15	0	126	126	35	60	25	100	235	104	265
CHV085.70	70°	248,86	160,81	5	114	109	15	40	35	60	245	82,5	275
CHV085.75	75°	251,61	181,07	5	114	109	15	40	35	60	245	82,5	275



AERIAL CAM UNIT - OBEN HÄNGENDER SCHIEBER - UNITÀ A CAMME SOSPESA

X VIEW

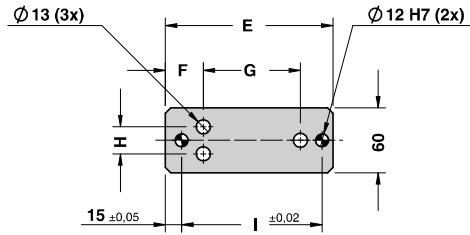
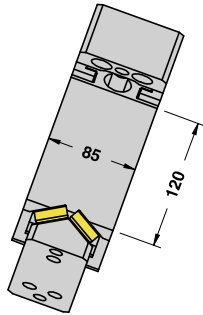

CAM DIAGRAM

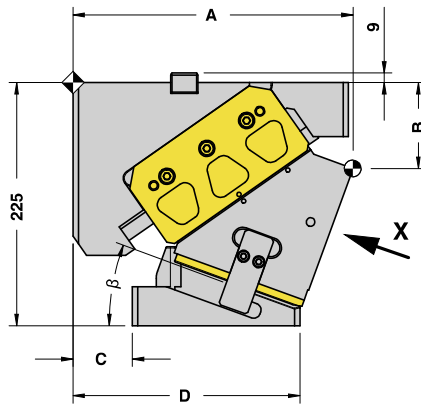
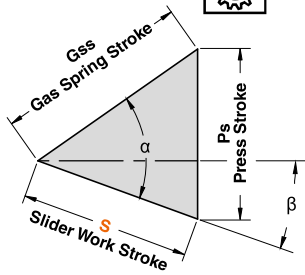

Work Angle	Inner Angle	Slider Work Stroke (mm)	Press Stroke (mm)	Gas Spring Stroke (mm)
β	α	S	Ps	Gss
0°	50°	30,85	36,77	48
5°	50°	34,07	36,91	48
10°	55°	34,46	39,93	48
15°	55°	38,07	40,71	48
20°	55°	41,84	41,84	48
25°	60°	43,38	45,87	48
30°	60°	48,00	48,00	48
35°	65°	50,75	53,11	48
40°	65°	56,79	56,79	48
45°	70°	42,30	43,85	33
50°	70°	48,24	48,24	33
55°	75°	54,06	55,57	33
60°	75°	63,75	63,75	33
65°	80°	75,42	76,90	33
70°	80°	95,02	95,02	33
75°	85°	95,13	96,23	25

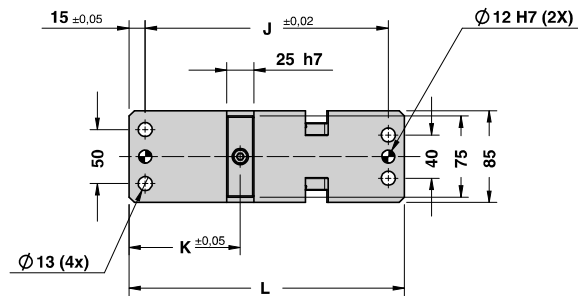

Cam Units CHV



AERIAL CAM UNIT - OBEN HÄNGENDER SCHIEBER - UNITÀ A CAMME SOSPESA

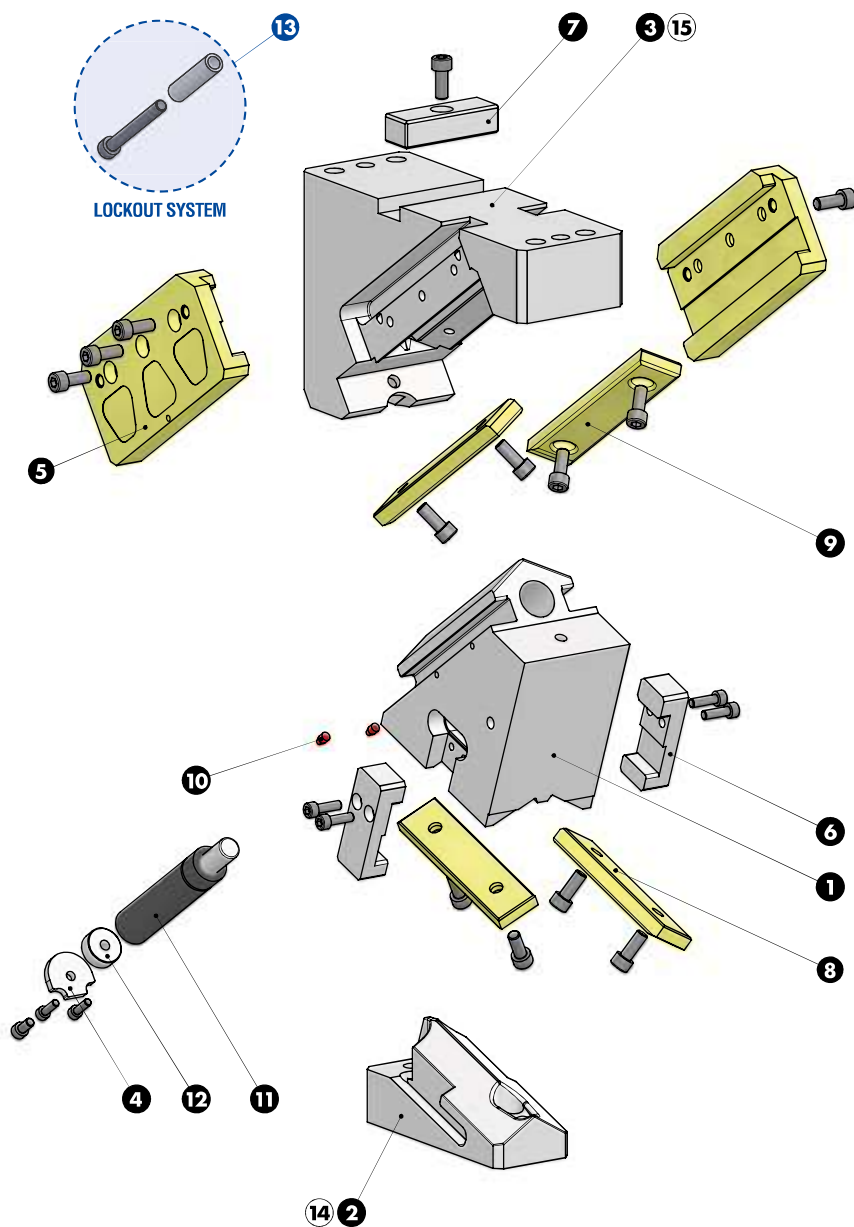



AERIAL CAM UNIT - OBEN HÄNGENDER SCHIEBER - UNITÀ A CAMME SOSPESA

SLIDER STRUCTURE, POSITIVE RETURN STRUCTURE AND CLEARANCES

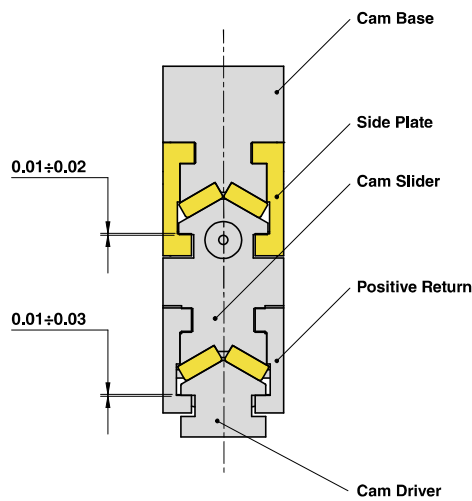

Cam Units CHV

PART LIST

Particular number	Description	Material	Quantity
1	Cam Slider	42CrMo4	1
2	Cam Driver	42CrMo4	1
3	Cam Base	42CrMo4	1
4	Lock Plate	42CrMo4	1
5	Side Plate	CuZn25Al5 + Graphite - HB > 190	2
6	Positive Return	42CrMo4 Nitrided	2
7	Key	CK45	1
8	Wear Plate VDI 3357	CuZn25Al5 + Graphite - HB > 190	2
9	Wear Plate VDI 3357	CuZn25Al5 + Graphite - HB > 190	2
10	Elastomer Cap	Elastomer 92SH	2
11	Gas Spring	-	1
12	Spring Spacer	CK45	1
13	LOCKOUT SYSTEM	<i>(more info on OMCR website)</i>	1
14	Cam Driver Fixing Screws M12x35 DIN 912	-	3
15	Cam Base Fixing Screws M12x65 DIN 912	-	4