

SI-HGZ63FQDRR

Safety Technology – Hinge Safety Switch

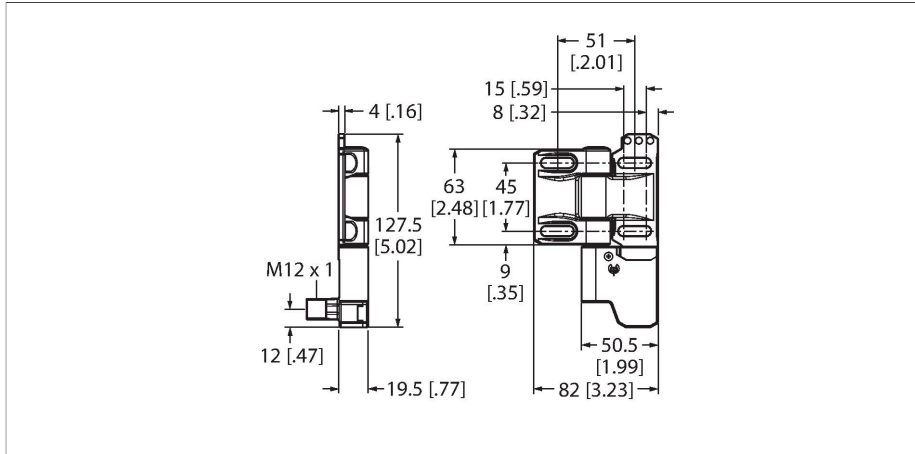

Technical data

Type	SI-HGZ63FQDRR
ID	3025584
Function	Hinge safety switch
Output function	2 x NC (normally closed), Potential-free
Rated insulation voltage	250 V
Conventional thermal current	4 A
Impulse withstand voltage	2.5 kV
Protection class	II
Design	Rectangular
Dimensions	82 x 39.5 x 127.5 mm
Housing material	Metal, Zinc Alloy Die-Cast
Switching speed	5 /min
Mechanical lifespan	1 * 10 ⁶ Switching cycles
B10d value	2 * 10 ⁶ Switching cycles
Cascadable	No
Electrical connection	Connector, M12 x 1
Number of cores	6
Ambient temperature	-25...+70 °C
Protection class	IP67
Special features	Wash down
Tests/approvals	
PL acc. to DIN EN 13849-1:2008	e
Category acc. to DIN EN 13849-1:2008	4
SIL according IEC 61508	3
Coding level/tamper protection	Uncoded

Features

- Door hinge switch
- Fulfills IEC 60947-5-1
- Safety interlock switch integrated in a very robust PBT housing
- Switchpoint is repositionable
- Tamper-proof
- Switchpoint is adjustable from 0° to 270° degrees
- Switch can be turned and operated from the opposite side
- Zinc die-cast hinge supports a load of 1200 N (120 kg)
- Right hinge
- Angled connector
- 2 safety outputs, NC
- 1 auxiliary contact, NO
- SIL 3 (IEC 61508)
- PL e (ISO 13849-1)

Functional principle

Use the SI-HG (Z)-63 series to monitor the position of a safety guard such as opening or removing.

A safety guard may be a gate, door, ceiling, panel, barrier or other physical means which separates a person from a hazard.

Safety interlock switches give a signal to the machine control to prevent a dangerous situation or to stop when the guard is not in the correct position.

These safety interlock switches are designed for non-locking safe guards, unless another guard is provided.